

Clariflo®

PUMP



SWIMMING POOL PUMP

MODEL NO: SPPT1

PART NO: 7175040

OPERATION & MAINTENANCE INSTRUCTIONS

UK
PA | CE



ORIGINAL INSTRUCTIONS

GC1123 - Rev 5

INTRODUCTION

Thank you for purchasing this CLARKE Swimming Pool Pump.

Before attempting to operate the pump, it is essential that you read this manual thoroughly and carefully follow all instructions given. In doing so you will ensure the safety of yourself and that of others around you, and you can also look forward to the pump giving you long and satisfactory service.

Upon receipt, any damage or deficiency should be reported to your CLARKE dealer immediately.

DESCRIPTION

This centrifugal swimming pool pump is designed for the filtration of small to medium size swimming pools and for pumping clean water only and operating with contaminated or salt water should be avoided.

When used with permanently installed pools, the pump should be fixed in a horizontal position and the use of a non-return valve will facilitate immediate priming. The pump inlet is higher than the impeller inlet so that it can start operating when only the pump body is filled with water.

The SPPT1 incorporates an integral timer which can be set to operate for a pre-determined time between 2 and 24 hrs. The timer has a back up battery to save the settings in case of loss of electrical power, allowing the pump to start again once power is restored.

GUARANTEE

This product is guaranteed against faulty manufacture for a period of 12 months from the date of purchase. Please keep your receipt which will be required as proof of purchase.

This guarantee is invalid if the product is found to have been abused or tampered with in any way, or not used for the purpose for which it was intended.

Faulty goods should be returned to their place of purchase, no product can be returned to us without prior permission.

This guarantee does not effect your statutory rights.

GENERAL SAFETY PRECAUTIONS



WARNING: THIS SWIMMING POOL PUMP IS NOT A SUBMERSIBLE PUMP. ON NO ACCOUNT SHOULD IT EVER BE IMMERSSED IN WATER.

WARNING: ALWAYS CONNECT THE PUMP TO AN EARTHED POWER SUPPLY VIA A RCD.

1. **ALWAYS** keep the pump room clean and well lit. Floors should always be kept clear. Cluttered or dark areas invite accidents.
2. **NEVER** over-reach. Keep your proper footing and balance at all times when installing or maintaining the pump.
3. **NEVER** direct any water discharge towards electrical wiring or equipment.
4. **ALWAYS** thoroughly familiarise yourself with this pump & its operation, and follow all instructions in this manual. Never allow persons unfamiliar with these instructions to operate the pump.
5. **ALWAYS** ensure that the pump is properly installed to prevent it from moving during operation, and that the immediate area surrounding the pump is kept clear.
6. **ALWAYS** maintain the pump with care and keep it clean for best / safest performance.
7. **NEVER** use this product if any part is damaged. Have it inspected and repaired by your local CLARKE dealer. Always turn the pump off before carrying out any maintenance.
8. **NEVER** modify this pump in any way. Use it ONLY for the purpose for which it is designed.
9. **NEVER** use for pumping flammable liquids or corrosive chemicals. This pump is designed to pump clean water only.
10. **NEVER** switch the pump ON when the pool is in use. ALWAYS disconnect the pump from the electrical supply when the pool is in use.
11. This pump must be connected to an earthed power supply via a RCD.
12. **ALWAYS** have the pump serviced by your local CLARKE dealer, using only identical replacement parts. This will ensure the safety of the pump is maintained. The use of non standard parts could be hazardous.
13. Your CLARKE water pump has been designed to give long and trouble free service. If, however, having followed the instructions in this booklet carefully, you encounter problems, take the unit to your local CLARKE dealer.

Please keep these instructions in a safe place for future reference.

ELECTRICAL CONNECTIONS



WARNING: READ THESE ELECTRICAL SAFETY INSTRUCTIONS THOROUGHLY BEFORE CONNECTING THE PRODUCT TO THE MAINS SUPPLY.

Connect the mains lead to a standard, 230 Volt (50Hz) electrical supply through an approved 13 amp BS 1363 plug, or a suitably fused isolator switch. If the plug has to be changed because it is not suitable for your socket, or because of damage, it must be removed and a replacement fitted, following the wiring instructions shown below. The old plug must be discarded safely, as insertion into a power socket could cause an electrical hazard.



**WARNING: THE WIRES IN THE POWER CABLE OF THIS PRODUCT ARE COLOURED IN ACCORDANCE WITH THE FOLLOWING CODE:
BLUE = NEUTRAL BROWN = LIVE YELLOW AND GREEN = EARTH**

If the colours of the wires in the power cable do not agree with the markings on the plug.

- The BLUE wire must be connected to the terminal marked N.
- The BROWN wire must be connected to the terminal marked L.
- The YELLOW AND GREEN wire must be connected to the terminal marked E or .

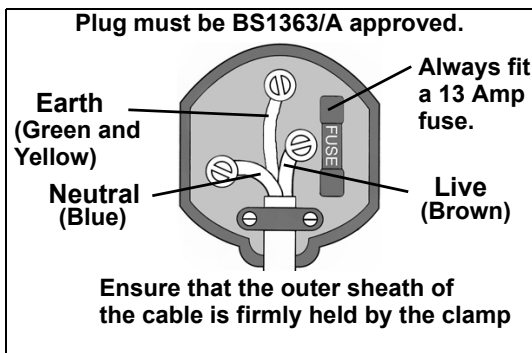

AN APPROVED RESIDUAL CURRENT DEVICE (RCD) WHICH HAS A TRIPPING CURRENT OF LESS THAN 30MA MUST BE USED.

If you are not sure, consult a qualified electrician. DO NOT try to do any repairs.

INSTALLATION

Because of the variety of possible installations, no plumbing accessories are supplied with your pump, however accessories are available from your nearest CLARKE dealer. Contact your CLARKE dealer for further information.

NOTE: It is recommended that the end user should consult a qualified installer if there are any doubts as to the suitability of this product for a particular installation.

IMPORTANT: The pump **MUST NOT** be connected to the mains power supply until all hose/pipe installation is completed.

INSTALLATION OF THE PUMP

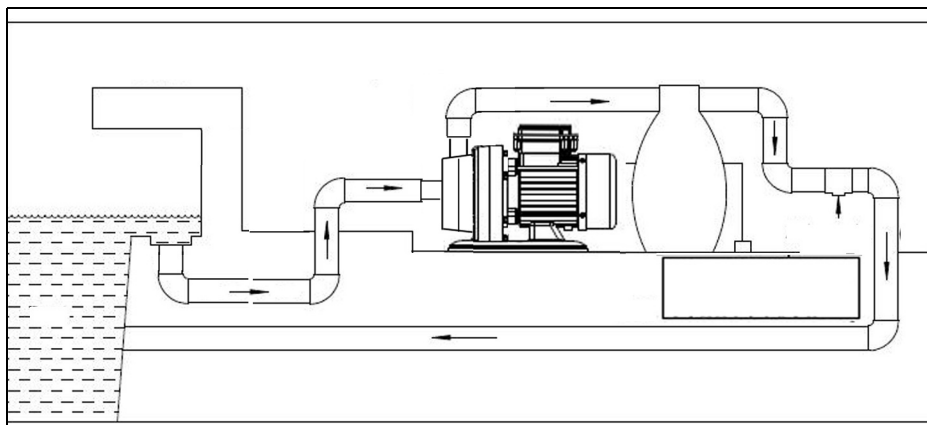

Fig 1

A typical installation of the pump is shown above. The pump must always be installed and operated in a horizontal position i.e. with the outlet port facing vertically upwards. The fixing holes in the base should be used to secure the pump firmly in its operating position. Mount the pump on raised blocks or a purpose built platform to protect it from flooding.

Always ensure there is adequate air circulation around the motor and that the transparent filter cover is accessible so that the filter basket can be removed for cleaning. The pump should be installed in a dry, well ventilated enclosure, sheltered from rain, such as a purpose built pump room.

The pump is usually installed between the pool skimmer and the pool filter and should be positioned as near to the pool water level as possible.

PIPE/HOSE CONNECTIONS

The pump inlet will be connected to the pool skimmer and/or pool drain connection, depending upon the installation layout, and the discharge outlet should be connected to your water filter.

The diameter of the inlet/outlet connectors is 40 mm. Therefore hoses with the same nominal diameter should be used and secured with a worm drive clip. Ensure all connections are air tight. Tighten them enough to secure the hose during pressurised operation, but not so tight as to crack the plastic inlet/outlet connectors.

Where the pump is to be a permanent fixture, vibration and strain on adjacent parts can be reduced by the insertion of a short flexible section of hose between any rigid pipework and the immediate area of the pump.

Any air leaks in the suction line will inhibit priming and reduce the capacity of the pump. Ensure there are no kinks in any flexible hose used.

The performance of your pump will be affected by the diameter of the inlet pipe - any restriction will greatly reduce the flow. We recommend that you always use a pipe diameter at least equal to, or greater than the diameter of the pump connections i.e. 50 mm diameter.

To prevent unnecessary strain or possible distortion to the pump, ensure that adequate support is provided to the hoses and or pipes. They will be considerably heavier when filled with water.

It is suggested that suction and delivery isolation valves are fitted in order to isolate the pump. A gate valve may be installed in-line on the delivery side (outlet port) of the pump which can be adjusted as required to regulate the flow of water and can assist in priming the pump.

Protect the pump and pipework from freezing with the addition of suitable lagging. The formation of ice may cause serious damage.

SUCTION LIFT OR GRAVITY FEED

The schematic diagrams, figs. 2 and 3, illustrate possible methods of pipework installation. This pump is designed primarily to be gravity fed, that is, drawing water from an above ground pool. However, it is possible to draw water from

a sunken pool, providing the suction lift does not exceed the distance specified for your pump. The suction lift i.e. the vertical distance between the water level and the pump should not exceed 7 metres.

A foot valve/filter must be fitted to the lower end of the suction hose, (as illustrated in fig 2), so as to help retain water in the suction system. Remember.... this is NOT a self priming pump.

When suction lift is used to draw water into the pump it is essential that all connections and hoses are completely air tight, otherwise the system will not work.

Before pumping it is essential to completely fill the suction side with water. This is known as priming the pump and is carried out as follows:-

1. With the pump, all inlet pipes/ hoses and the foot valve in position, slowly pour water into the outlet port. Wait until all air is expelled...this may take a minute or two...and fill to the brim before connecting the outlet hose to the outlet port. The hose is then connected to the water filter.
2. Switch on the pump. Water should start to flow through the system. Check for leaks and repair as necessary.

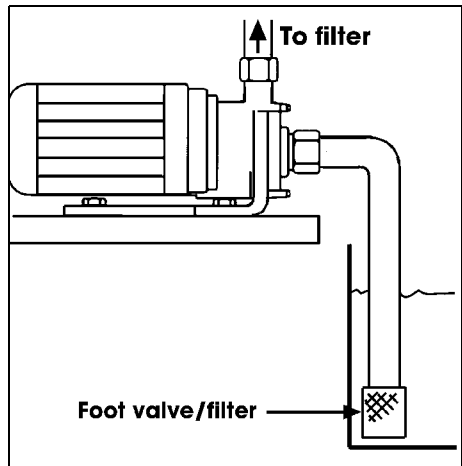

Fig 2:- Suction Lift

Do not allow the pump to run dry, otherwise the seal between the pump and motor may be damaged. If a leak is noticed at this point it may indicate that the seal is worn and therefore in need of replacement. Contact your CLARKE dealer, or the Clarke International Service Department for advice.

Do not place any restriction on the inlet side of the pump.

Remember - this pump is designed for pumping CLEAN WATER with small solids in suspension, ONLY. DO NOT USE for pumping chemicals or other corrosive liquids (other than pool purification chemicals in their correct mix ratio).

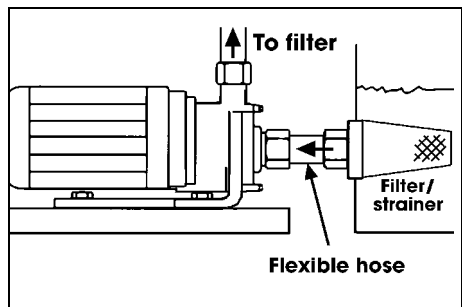

Fig 3: Gravity Feed

ELECTRICAL CONNECTION

The pump should be located at a safe distance, (usually 2 metres), away from the pool, and the power supply should be at least 3.5 metres from the pool. If in doubt, please contact your electrical specialist and refer to the International Electrical Commission (IEC) standard, (Electrical Installations for Buildings-part 7), referring to 'swimming pools and other basins'.

Avoid situations where the pump could become drenched with water as neither the motor or terminal box are designed to be waterproof. Ensure the pump & its cable do not create a safety hazard for people walking past it.

THE TIMER BATTERY

The timer is equipped with a CR2032 battery which is initially supplied in a film protective sleeve which must be removed before first use. Thereafter, battery life is usually around 3 years.

Ensure the pump is disconnected from the mains supply before unscrewing the top cover of the terminal box to install/replace the battery..



WARNING: ENSURE THE PUMP IS DISCONNECTED OR SWITCHED OFF AT THE MAINS SUPPLY BEFORE UNSCREWING THE TOP COVER

OPERATION

1. Open any valves in the pipeline.

NOTE: The pump is only self-priming when filled with water. Refilling is only necessary if the pump has been drained, or if the water has been lost.

2. Connect to the power supply and switch on. Water should start to flow through the system. Check for any leaks and repair as necessary.
3. If the motor fails to start, or the pump does not deliver water, refer to TROUBLESHOOTING on page 9. Never operate the pump when not filled with water or if the inlet is blocked.

NOTE: Filling the suction pipe with water will speed up the priming process, and it is suggested that a non-return valve be fitted to the end of the suction pipe.

4. Stop the pump by switching off the power supply.

SETTING THE TIMER

The programmable timer provides operation for 2 to 24 hour periods in 2 hour increments up to 16 hours. When the pump is connected to the power supply one LED will always be

on. A backup battery is provided to save the settings in case the electrical power supply is disconnected. If power is lost, the pump will start automatically as soon as power is restored.

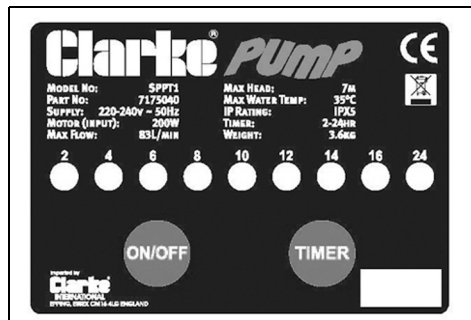

The duration of the cycle remaining can be seen by the status of the LEDs.

For example, to set the pump for 6 hours running in a 24 hour period:

1. Press the timer until the "6" LED turns red.

2. Press the ON/OFF button and the 6 hour running period will start.
3. Switch the pump off by pressing the ON/OFF button.

CARE DURING USE

1. Do not allow the pump to run dry, otherwise the seal between the pump and motor may be damaged. If a leak is noticed at this point, it may indicate that the seal is worn and therefore in need of replacement. Contact your CLARKE dealer, or the CLARKE International Service Department for advice.
2. In the event of a blockage, where debris has entered the suction chamber, it can be cleaned out as described under MAINTENANCE.
3. Should contaminants come into contact with the pump, flush through with cold water as soon as possible to prevent damage to the pump. DO NOT USE for pumping chemicals or other corrosive liquids (other than pool purification chemicals in their correct mix ratio).
4. If the pump is being used to drain the pool, ensure there is adequate drainage and there is no risk of damage to property as a result of water being discharged. If a flexible hose must be laid across a roadway, protect it with wooden planking.

MAINTENANCE

The only maintenance required is a regular inspection to ensure that debris is not blocking the passage of water through the pump.

If you suspect the pump is blocked by silt, leaf debris etc, disconnect it from the mains supply and backflush to clear any blockage through the drain plug. You will need to disconnect the outlet hose to do this.

Always keep the pump in a clean condition, checking regularly for loose bolts or a damaged power cable etc.

The pump should not be taken apart by the user in the case of overhaul being required, but should be taken to your nearest Clarke dealer for specialist repair.

AFTER USE

After use, and if the pump will not be used over the winter period, or whenever there is danger of freezing, always drain the pump body. If the pump has been used with contaminated or salty water, it should be thoroughly flushed with clean water following use, both inside and out. It should then be drained before replacing the drain plug, and covered over, if not already installed in a clean, dry environment sheltered from the weather. Remember to re-prime the pump when returning to service.

In the event that dismantling and overhaul of the pump is necessary, contact your CLARKE International Service Department on 020-8988-7400

ENVIRONMENTAL PROTECTION



Any redundant accessories and packaging should be sorted and taken to a recycling centre to be disposed of appropriately.

Through the purchase of this product, the customer is taking on the obligation to deal with the WEEE in accordance with the WEEE regulations in relation to the treatment, recycling & recovery and environmentally sound disposal of the WEEE.

In effect, this means that this product must not be disposed of with general household waste. It must be disposed of according to the laws governing Waste Electrical and Electronic Equipment (WEEE) at a recognised disposal facility.

TROUBLESHOOTING

PROBLEM	CAUSE	SOLUTION
Pump does not run.	No mains supply	Check fused power supply and replace fuse if necessary (check fuse rating). Check circuit breaker.
	Impeller seized/blocked	Disconnect pump from mains supply. Investigate cause and clear blockage.
Pump fails to prime	Air leaks through suction hose joints (damaged hose, broken clamp, damaged/ill-fitting gasket)	Repair connections/replace hose as necessary.
	Blocked inlet hose.	Check pipeline and pool skimmer for blockage. Check any inlet valve fitted is fully open.
Pump runs but give poor output	Pump inlet filter basket is blocked.	Check and clean filter basket.
	Congested material inside pump.	Clean out filter basket & backflush pump.
	Suction or delivery line obstructed.	Remove obstruction and ensure there are no kinks in delivery line.
	Inlet pipe leakage.	Check inlet pipe and connector for leaks. Tighten as required.
	Air leaks through damaged seal.	Renew seal.
	Impeller damaged and making poor seal.	Return to your CLARKE dealer for repair.
	Impeller / mechanical seal is badly worn.	Return to your CLARKE dealer for repair.
	High friction losses in the suction line.	Avoid unnecessary curves, restrictions or valves.
	Pump badly sited resulting in suction lift too high.	Set pump as close as possible to the level of the water to be pumped.

PROBLEM	CAUSE	SOLUTION
Sudden loss of flow.	Blockage of inlet pipe.	Check pipeline and pool skimmer for blockage.
Undue vibration or noise.	Excessive flow of water.	Decrease flow of water. by adjusting inlet/outlet valves in system.
	Resistance in inlet pipe caused by obstruction	Check pipe and clean out as necessary.
	Loose rotating component	Return to your CLARKE dealer for repair.
	Installation of pump is unstable.	Stop pump and re-position.
	Air pocket in pump or pipeline.	Release drain plug in impeller housing to release air.
	Damaged impeller	Return to your CLARKE dealer for repair.

If this does not solve your problem, please contact the CLARKE service department.

SPPT1 PERFORMANCE

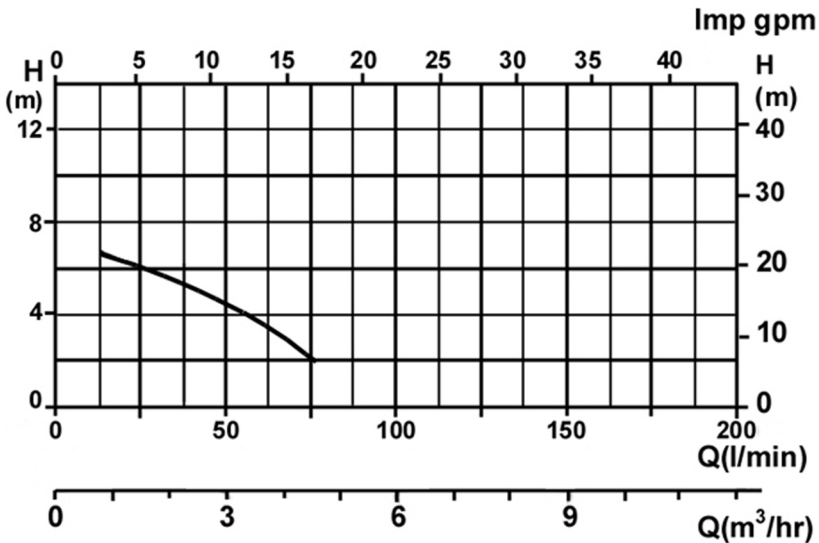

TECHNICAL DATA

Dimensions (L x W x H)	307 x 142 x 220 mm
Weight	3.6 kg (8Lb)
Inlet & Outlet Size	40 mm
Max Flow	83 L/min
Max Head	7 m
Operating Temperature	35°C
Suitable Water Type	Swimming Pools/Clean Water
Power Supply	220-240V @ 50Hz
Sound Pressure Level	68.6 dB LpA
Sound Power Level	69.3 dB LwA
Guaranteed Sound Power	73 dB LwA
Timer Run Times	2 hour increments - 24 hours
Power Cable Length	1.8 m

Please note that the details and specifications contained herein, are correct at the time of going to print. However, CLARKE International reserve the right to change specifications at any time without prior notice.

DECLARATION OF CONFORMITY - UKCA, P1 OF 2

**UK
CA**

Clarke[®]
INTERNATIONAL

Hemnoll Street, Epping, Essex CM16 4LG

DECLARATION OF CONFORMITY

This is an important document and should be retained.

Product Description: 200W Swimming Pool Pump
Model number(s): SPPT1
Serial / batch Number: N/A
Date of Issue: 18/03/2022
(Noise Conformity)
Notified Body: n/a

Technical Documentation Holder: A.R. Pond
Clarke International
2a Shrubland Road
London E10 7RB
UK

Conformity Assessment Procedure: to 2000/14/EC Annex VI
Manufacturer: Clarke International
Noise Related Value: 0.2kW
Measured Sound Power Level: 59 dB
Guaranteed Sound Power Level: 71 dB

DECLARATION OF CONFORMITY - UKCA, P2 OF 2

**UK
CA**

Clarke[®]
INTERNATIONAL

Hemnoll Street, Epping, Essex CM16 4LG

DECLARATION OF CONFORMITY

This is an important document and should be retained.

We hereby declare that this product(s) complies with the following statutory requirement(s):

Electromagnetic Compatibility Regulations 2016

Electrical Equipment (Safety) Regulations 2016

The Restriction of the Use of Certain Hazardous Substances in Electrical and Electronic Equipment Regulations 2012

Noise Emission in the Environment by Equipment for Use Outdoors Regulations 2001

The following standards have been applied to the product(s):

EN 55014-1:2006/A2:2011, EN 55014-2:2015, EN 61000-3-2:2014, EN 61000-3-3:2013,

EN 60335-2-41:2003/A2:2010, EN 60335-1:2012/A2:2019, EN 62321-1:2013, EN 62321-2:2014,

EN 62321-3-1:2014, EN 62233:2008.

The technical documentation required to demonstrate that the product(s) meet(s) the requirement(s) of the aforementioned legislation has been compiled and is available for inspection by the relevant enforcement authorities.

The UKCA mark was first applied in: 2022

Signed:



J.A. Clarke
Director

DECLARATION OF CONFORMITY - CE, P1 OF 2



Clarke[®]
INTERNATIONAL

Fitzwilliam Hall, Fitzwilliam Place, Dublin 2

DECLARATION OF CONFORMITY

This is an important document and should be retained.

Product Description: 200W Swimming Pool Pump
Model number(s): SPPT1
Serial / batch Number: N/A
Date of issue: 18/03/2022
(Noise Conformity)
Notified Body: n/a

Technical Documentation Holder: A.R. Pond
Clarke International
2a Shrubland Road
London E10 7RB
UK

Conformity Assessment Procedure: to 2000/14/EC Annex VI
Manufacturer: Clarke International
Noise Related Value: 0.2kW
Measured Sound Power Level: 59 dB
Guaranteed Sound Power Level: 71 dB

DECLARATION OF CONFORMITY - CE, P2 OF 2



Clarke[®]
INTERNATIONAL

Fitzwilliam Hall, Fitzwilliam Place, Dublin 2

DECLARATION OF CONFORMITY

This is an important document and should be retained.

We hereby declare that this product(s) complies with the following directive(s):

- 2014/30/EU *Electromagnetic Compatibility Directive*
- 2014/35/EU *Low Voltage Equipment Directive*
- 2011/65/EU *Restriction of Hazardous substances (amended by (EU) 2015/863)*
- 2000/14/EC *Noise Emissions Directive, (amended by 2005/88/EC).*

The following standards have been applied to the product(s):

- EN 55014-1:2006/A2:2011, EN 55014-2:2015, EN 61000-3-2:2014, EN 61000-3-3:2013,*
- EN 60335-2-41:2003/A2:2010, EN 60335-1:2012/A2:2019, EN 62321-1:2013, EN 62321-2:2014,*
- EN 62321-3-1:2014, EN 62233:2008.*

The technical documentation required to demonstrate that the product(s) meet(s) the requirement(s) of the aforementioned directive(s) has been compiled and is available for inspection by the relevant enforcement authorities.

The CE mark was first applied in: 2012

Signed:

J.A. Clarke
Director

PARTS DIAGRAM

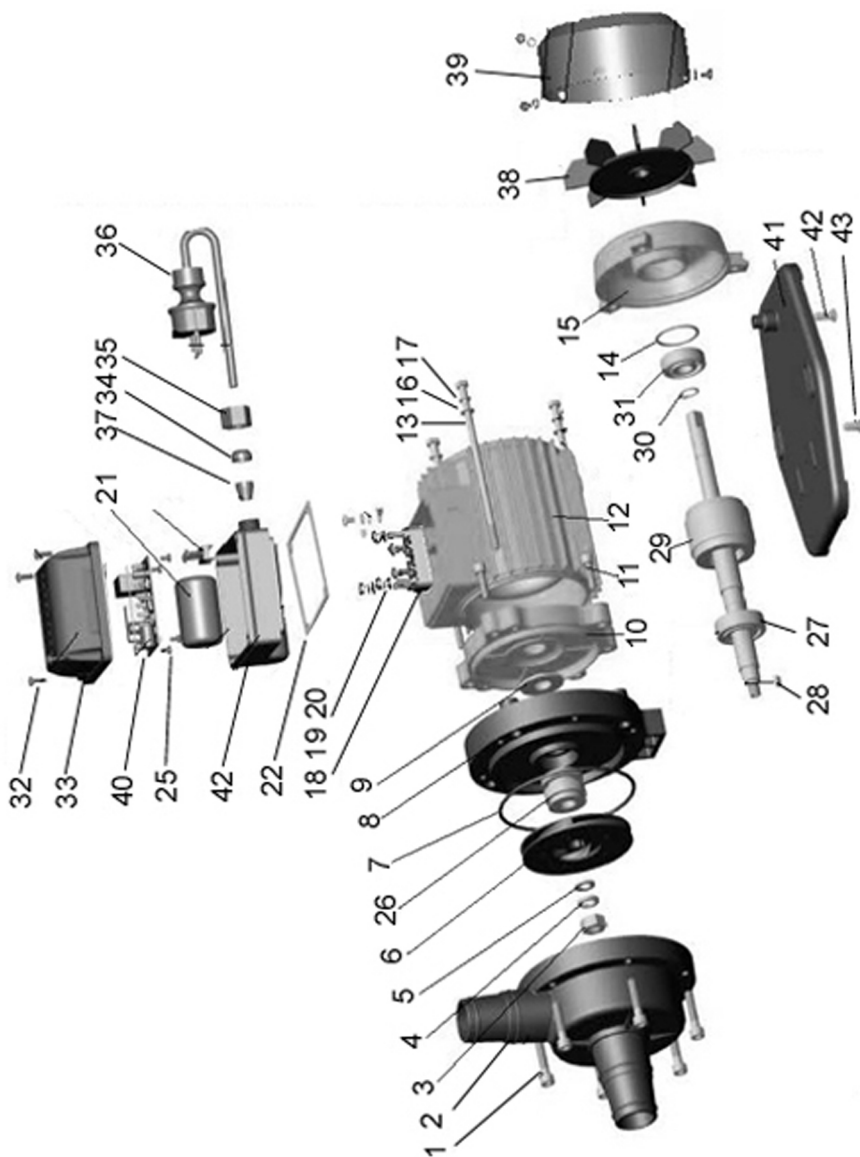

PARTS LIST

No	Description
1	Socket headed bolt
2	Impeller housing
3	Nut
4	Flat washer
5	Washer
6	Impeller
7	O-ring seal
8	Mounting frame
9	Water seal
10	Motor cover
11	Socket headed bolt
12	Motor stator assembly
13	Socket headed stud bolt
14	Wave washer
15	Rear cover
16	Flat washer
17	Spring washer
18	Terminal block
19	Brass washer
20	Brass nut
21	Capacitor
22	Gasket

No	Description
23	Screw
24	Star washer
25	Self tapping screw
26	Main seal
27	Ball race
28	Key
29	Armature
30	Circlip
31	Bearing
32	Screw
33	Control box cover
34	Plastic washer
35	Gland sealing nut
36	Power cable
37	Sealing gland
38	Fan
39	Fan cover
40	Printed circuit board
41	Mounting base
42	Control box body
43	Rear mounting screw
44	Front mounting screw

ACCESSORIES

A wide range of accessories is available, including foot valve filters, suction and layflat hoses and clips, couplings and 90° hose adaptors, etc.

Contact your Clarke dealer for further information. The use of parts other than genuine Clarke replacement parts may result in possible safety hazards or decreased pump performance and will invalidate your warranty.

A SELECTION FROM THE VAST RANGE OF

Clarke®

QUALITY PRODUCTS



AIR COMPRESSORS

From DIY to industrial, Plus air tools, spray guns and accessories.

GENERATORS

Prime duty or emergency standby for business, home and leisure.

POWER WASHERS

Hot and cold, electric and engine driven - we have what you need

WELDERS

Mig, Arc, Tig and Spot. From DIY to auto/industrial.

METALWORKING

Drills, grinders and saws for DIY and professional use.

WOODWORKING

Saws, sanders, lathes, mortisers and dust extraction.

HYDRAULICS

Cranes, body repair kits, transmission jacks for all types of workshop use.

WATER PUMPS

Submersible, electric and engine driven for DIY, agriculture and industry.

POWER TOOLS

Angle grinders, cordless drill sets, saws and sanders.

STARTERS/CHARGERS

All sizes for car and commercial use.

PARTS & SERVICE:

0208 988 7400

Parts Enquiries

Parts@clarkeinternational.com

Servicing & Technical Enquiries

Service@clarkeinternational.com

SALES: UK 01992 565333 or Export 00 44 (0)1992 565335

Clarke INTERNATIONAL Hemnall Street, Epping, Essex CM16 4LG
www.clarkeinternational.com